

# **METAL-FACH**

16-100 SOKÓŁKA, POLAND

UL. KRESOWA 62

**OPERATING MANUAL  
PARTS CATALOGUE**

**MANURE SPREADER**

**N280**

**N280/1**

**N280/2**

Edition no. 01

Year of issue: 2012

The original operating manual language is Polish.



# CE DECLARATION OF CONFORMITY



## FOR THE MACHINE

„METAL-FACH” Sp. z o.o.  
ul. Kresowa 62  
16-100 SOKÓŁKA

*which acts as the manufacturer*

**declares under sole responsibility that the following machine:**

### Manure spreader

type/model N280-.....

year of manufacture: .....

serial number: .....

**this declaration concerns, meets the following requirements:**

- Directive 2006/42/EC OF THE EUROPEAN PARLIAMENT AND OF THE COUNCIL dated 17 May 2006 on machines, and amending Directive 95/16/EC (Official Journal EU L157 of 09/06/2006, p. 24) and the Resolution of the Minister of Economy of 21 October 2008 concerning general requirements for machinery (Journal of Laws No. 199 item 1228).

**The following harmonised standards were used for compliance evaluation:**

PN-EN 690+A1:2009	PN-EN ISO 4254-1: 2009 + AC:2010
PN-EN ISO 12100:2011	PN-EN ISO 13857:2010

- and the following standards: PN-ISO 3600:1998, PN-ISO 11684:1998; and the Resolution of the Ministry of Infrastructure of 31 December 2002 on technical requirements for vehicles and the scope of their necessary equipment (Journal of Laws issue 32 item 262 as amended).

**Safe Use Test Report No.**

Unit responsible for engineering documentation: Engineering and Design Department

**This Declaration of Conformity becomes void and null if the machine design is changed or modified in any manner without prior consent from the manufacturer.**

Sokolka

President of the Management Board  
**Jacek Marek Kucharewicz**

## CONTENTS:

<b>1. INTRODUCTION .....</b>	<b>5</b>
<b>2. SAFETY INSTRUCTIONS .....</b>	<b>6</b>
2.1. RESIDUAL RISKS .....	7
2.2. NOISE AND VIBRATION .....	8
<b>3. INFORMATION AND WARNING SIGNS.....</b>	<b>8</b>
<b>4. INTENDED USE .....</b>	<b>14</b>
<b>5. OPERATION OF SPREADERS .....</b>	<b>14</b>
5.1. COUPLING THE SPREADER WITH THE TRACTOR.....	14
5.1.1. ADAPTER DRIVE.....	16
5.1.2. COMMISSIONING AND RUNNING-IN.....	17
5.2. ELECTRICAL SYSTEM .....	17
5.3. LOAD BODY GATE CONTROL .....	18
5.4. FLOOR CONVEYOR.....	18
5.4.1. HYDRAULIC DRIVE OF THE FLOOR CONVEYOR.....	18
5.4.2. MANURE DOSING .....	19
5.5. ADJUSTMENT OF CONVEYOR CHAIN TENSION .....	20
5.6. SPREADING ADAPTER.....	21
5.7. BRAKES ADJUSTMENT.....	22
5.7.1. PARKING BRAKE ADJUSTMENT.....	22
5.7.2. SERVICE BRAKE ADJUSTMENT.....	22
5.8. ADJUSTMENT OF THE LAND WHEELS CLEARANCE.....	23
<b>6. MAINTENANCE AND SERVICING.....</b>	<b>23</b>
6.1. HYDRAULIC SYSTEM SERVICING.....	23
6.2. PNEUMATIC SYSTEM SERVICING.....	24
6.3. PERIODIC MAINTENANCE .....	24
6.4. LUBRICATION.....	25
<b>7. TECHNICAL CHARACTERISTICS .....</b>	<b>26</b>
<b>8. MAINTENANCE, CARE AND STORAGE .....</b>	<b>27</b>
<b>9. DISMANTLING, DISPOSAL AND ENVIRONMENTAL PROTECTION .....</b>	<b>27</b>
<b>10. EQUIPMENT.....</b>	<b>28</b>
<b>11. USE.....</b>	<b>29</b>
<b>12. DESIGN AND OPERATING PRINCIPLE OF THE SPREADER .....</b>	<b>29</b>



METAL -FACH Sp. z o.o.  
ul. Kresowa 62 16-100 Sokółka,  
Poland www.metalfach.com.pl

## Rozrzutnik obornika

Typ  Wariant

KJ  Masa własna  kg

Nacisk na zaczep  kN

Nr fabr.

Dopuszczalna masa całkowita  kg

Dopuszczalne obciążenie osi  kN



Nameplate

## **INFORMATION!**

**FAILURE TO FOLLOW THE RULES AND GUIDELINES INCLUDED IN THESE INSTRUCTIONS  
MAY RESULT IN DEATH OR SEVERE BODY INJURY!**

# **1. INTRODUCTION**

The user of this product should read and understand these Operating Instructions in full, as well as follow all the guidelines contained herein to ensure safe operation of this machine. The Instructions include the description of the design and operating principle, technical characteristics and rules of intended use and servicing of the machine. Exercise extreme caution when in doubt about any procedure or operation. Should you have any questions, consult the authorised seller or the manufacturer.



Hazard warning sign

This sign denotes important information on the operating safety, which must be read in full and relayed to all the service personnel if necessary. The information included in the Instructions contain the basic guidelines for proper operation and servicing, as well as about the operating safety and health regulations.

Pursuant to the Resolution of the Ministry of Infrastructure of 31 December 2002 on technical requirements for vehicles and the scope of their necessary equipment, we hereby notify that farming tractors and slow-moving vehicles, as well as trailer units designed for coupling with these vehicles must feature an identification emblem. The emblems are not required for a vehicle included in a string of vehicles which is not the last vehicle in the string. We follow this requirement by equipping our vehicles with special mounting frames which are located on the spreader adapter guard. Always mount the identification emblem for travelling on public roads. Place the emblem in the tractor cab when the spreader is on duty.

The N280 spreader conforms to the traffic code regulations regarding the traffic of machines with the maximum speed of 30 km/h on public roads. The machine also conforms to the safety requirements of the valid regulations for the agricultural machines of this type.

## 2. SAFETY INSTRUCTIONS



Always turn off the tractor engine, remove the ignition key and engage the parking brake before leaving the driver's seat.

Should any failure occur, always turn off the tractor engine.



Do not turn on the conveyor when the adapter is off. Prior to starting your work, first lift the body gate, engage the adapter, run it at the full PTO speed and then turn on the floor conveyor drive.



Before attempting to work on any systems of the spreader connected to the tractor with the drive-shaft, turn off the tractor engine and remove the ignition key. Decouple the drive-shaft before servicing (maintenance, repairs) the machine. Engage the spreader parking brake and chock the wheels.



Do not remain in the load body when the drive is on. Do not enter the spread zone when the spreader is working. Ensure that no persons are in the spread zone.



Do not exceed the permissible payload and driving speed, otherwise the machine may be damaged and the traffic safety may be compromised. Adapt the driving speed to the conditions when working or travelling on a rough terrain. Follow the traffic code regulations when travelling on public roads.



Do not use the floor conveyor to unload such materials as coal, wood, stone or construction materials.



Do not use the machine on a terrain with an inclination exceeding 8.5°.

Note that during the unloading the machine will change its impact on the tractor and its manoeuvring conditions.



Operation of the spreader without the system guards, riding on the spreader and its tow bar or driving without the connected braking system is strictly forbidden. The driver's mesh guard must be installed on the front end of the load body. The upper edge of the mesh guard must be at least 2.6 m from the ground surface. The telescopic jointed shaft must always be equipped with the full guard.



The mesh guard must be positioned to secure the adapter drums when towing the spreader on public roads. Spreaders equipped with the body gate can only travel on public roads with the gate closed.



The spreader can be operated only by adult personnel with a valid tractor driving licence. It is strictly forbidden to operate the machine when under the influence of alcohol or drugs.



Exercise due caution when performing any disassembly to prevent personal injury. If your skin is cut, wash the wound thoroughly, disinfect with medical hydrogen peroxide solution and seek medical attention. Any wound fouled with manure may result in Tetanus bacteria infection.

## 2.1. RESIDUAL RISKS

The N280 spreader has been designed and produced in accordance to the state of technology and safety requirements valid for its year of manufacture.

The manufacturer of this spreader has taken every effort in its design, production and labelling to eliminate all hazards related to operation, servicing and maintenance. However, there are specific unavoidable risk present.

Residual risk results from incorrect or improper conduct of the operating personnel. The greatest hazards occur during the following forbidden actions: The spreader is operated by minors or persons who are unfamiliar with the operating instructions; The spreader is operated by persons under the influence of alcohol or other intoxicants; Performance of any work on the spreader systems, when the spreader is coupled with the tractor with the running engine.

Attempting to work with the machine before inspecting the work site and environment;

Remaining on (aboard) the machine when it is working or in transit;

Use of telescopic jointed shafts without any guards;

Follow these guidelines and prohibitions:

- read and fully understand the operating instructions;
  - secure the machine against access by unauthorised persons and children;
  - cleaning, maintenance and repairs must be performed by adequately trained persons and with the PTO drive-shaft decoupled;
  - keep your hands out of hazardous spaces;
  - do not use the machine when it is not fit for duty and/or when the guards are missing;
  - do not use the telescopic jointed shafts without any guards;
  - no persons are allowed to remain near the machine when it is working;
  - no persons are allowed to remain on the machine when it is working or in transit;
  - do not use the machine without the connected and functioning braking and lighting systems;
- only then can you eliminate the residual risks to people and the environment when using this spreader.



**INFORMATION!**

The residual risks are present when the aforementioned rules are not followed.

## 2.2. NOISE AND VIBRATION

The operator is inside the tractor cab when the machine is working.

The equivalent sound pressure emission level A (LpA) is  $75.0 \pm 1$  dB.

The peak sound pressure value C (LCpeak) is  $82.0 \pm 1$  dB.

Machine sound power – N/A.

(Measurements acc. to PN-EN ISO 4254-1:2006 Annex B section 2.6)

No vibration hazards occur when working with this machine.

The operator's workstation is located in the tractor cab, with shock absorption and an ergonomically profiled seat. The value of the vibration exposure of the operator does not exceed  $0.5 \text{ m/s}^2$ .

## 3. INFORMATION AND WARNING SIGNS

Extremely hazardous areas are indicated with the yellow warning signs and warning labels placed on the machine. During operation of this machine, exercise extreme caution when remaining in direct proximity of these areas.

Check the serial number indicated in the Operating Instructions and the warranty card against the serial number stamped on the nameplate and the chassis frame. The nameplate and the stamped serial number are located on the chassis end sill, i.e. on the right side of the machine.



The warning stickers must always be legible. If the stickers become illegible, an assembly on which they are located is replaced or the machine is repainted, the stickers must be purchased at the retail outlets or ordered at your local dealer as spare parts and suitable replaced.

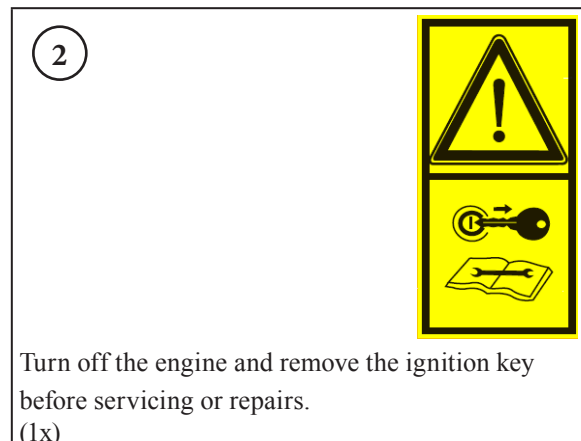
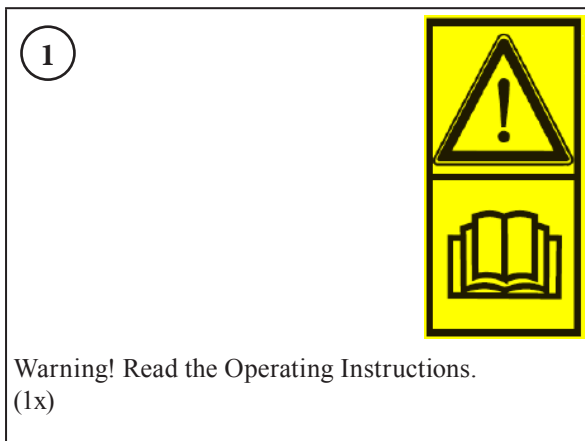



3   
540 RPM

PTO rotational speed: 540 RPM.  
(1x)

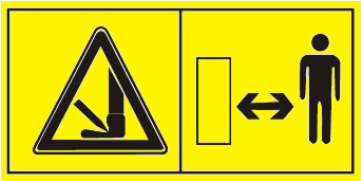
5 

Do not approach the working machine. Maintain a safe distance from the tow bar when it is being lifted or lowered.  
(1x)

7   
300 kPa

Tyre pressure.  
(2x)

9 

Lug for lifting hooks.  
(2x)

11   
Turn off the PTO drive at road turns.

Warning label.  
(1x)

4 

Do not remain between the machine and the tractor when the engine is running.  
(1x)

6 

Speed limit sign.  
(1x)

8 

Nameplate.  
(1x)

10   
Coupling only with the tractor's top transport hitch

Warning label.  
(1x)

12   
Do not enter the load body when the drive is on.

Warning label.  
(1x)

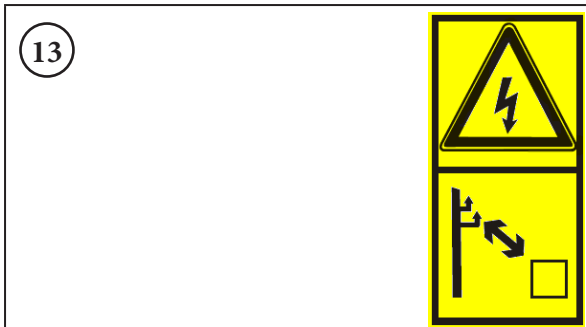

Keep a safe distance from power lines.  
(1x)



Information label  
(1x)



Information label – machine symbol.  
(2x)



Keep a safe distance from the adapter. Do not put your hands between the rotors.  
(2x)



Ejected objects. Keep a safe distance from the machine  
(2x)

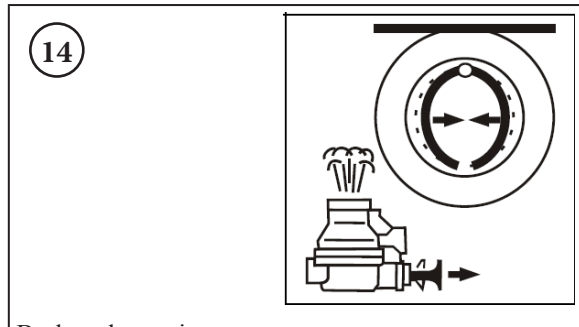

Brake release sign.  
(1x)



Information label – manufacturer's logo.  
(2x)

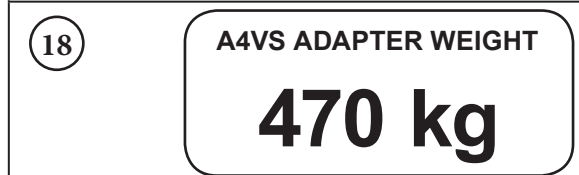

Description of the adapter weight.  
(2x)



Warning sign.  
(2x)



Lubrication points.  
(4x)



Warning of being caught by the PTO drive-shaft.  
(2x)

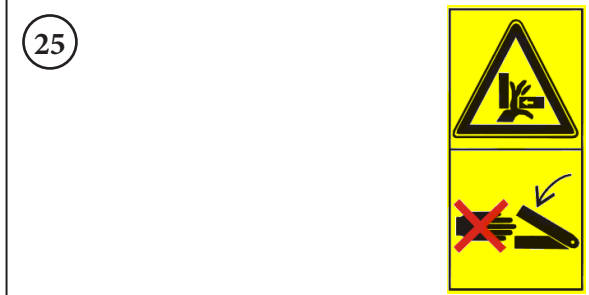

Danger of hands crushing.  
(2x)

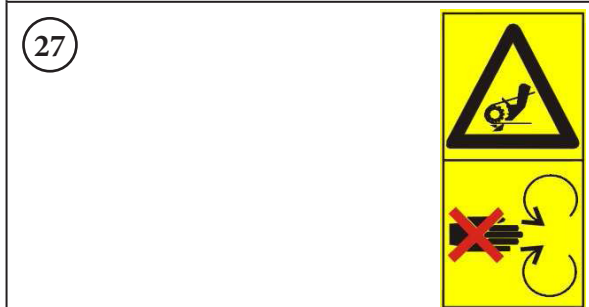

Danger of hand being caught by moving elements of the feeder  
(2x)



Do not ride on ladder steps or the tow bar. (1x)

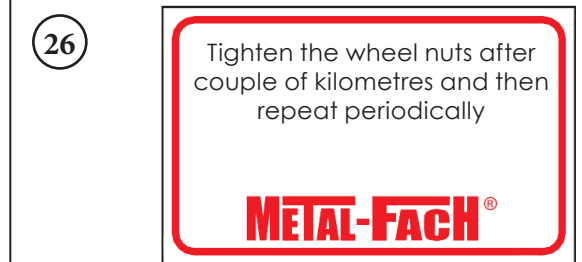

Tighten the wheel nuts after couple of kilometres and then repeat periodically

**METAL-FACH®**

Information on wheel tightening  
(2x)

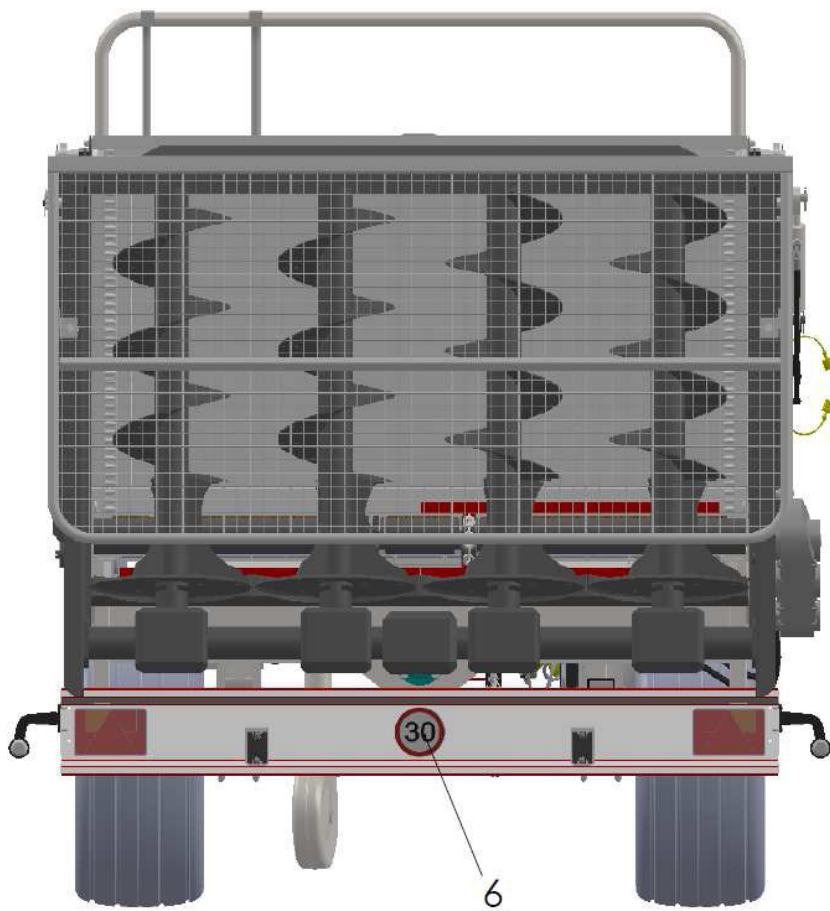
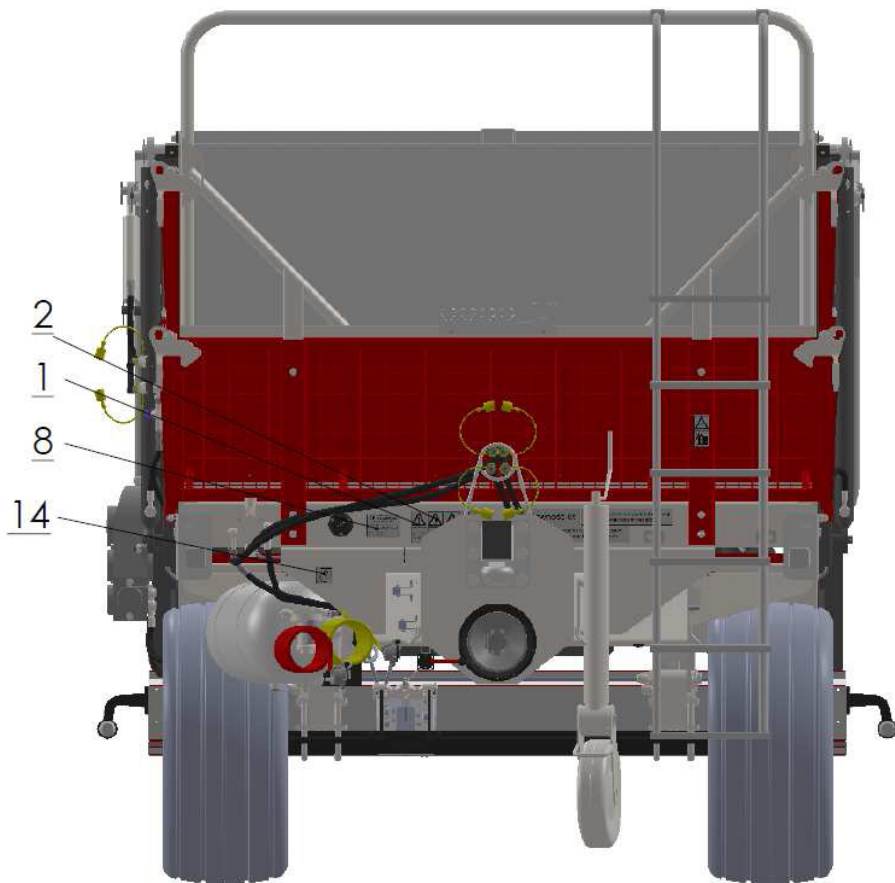

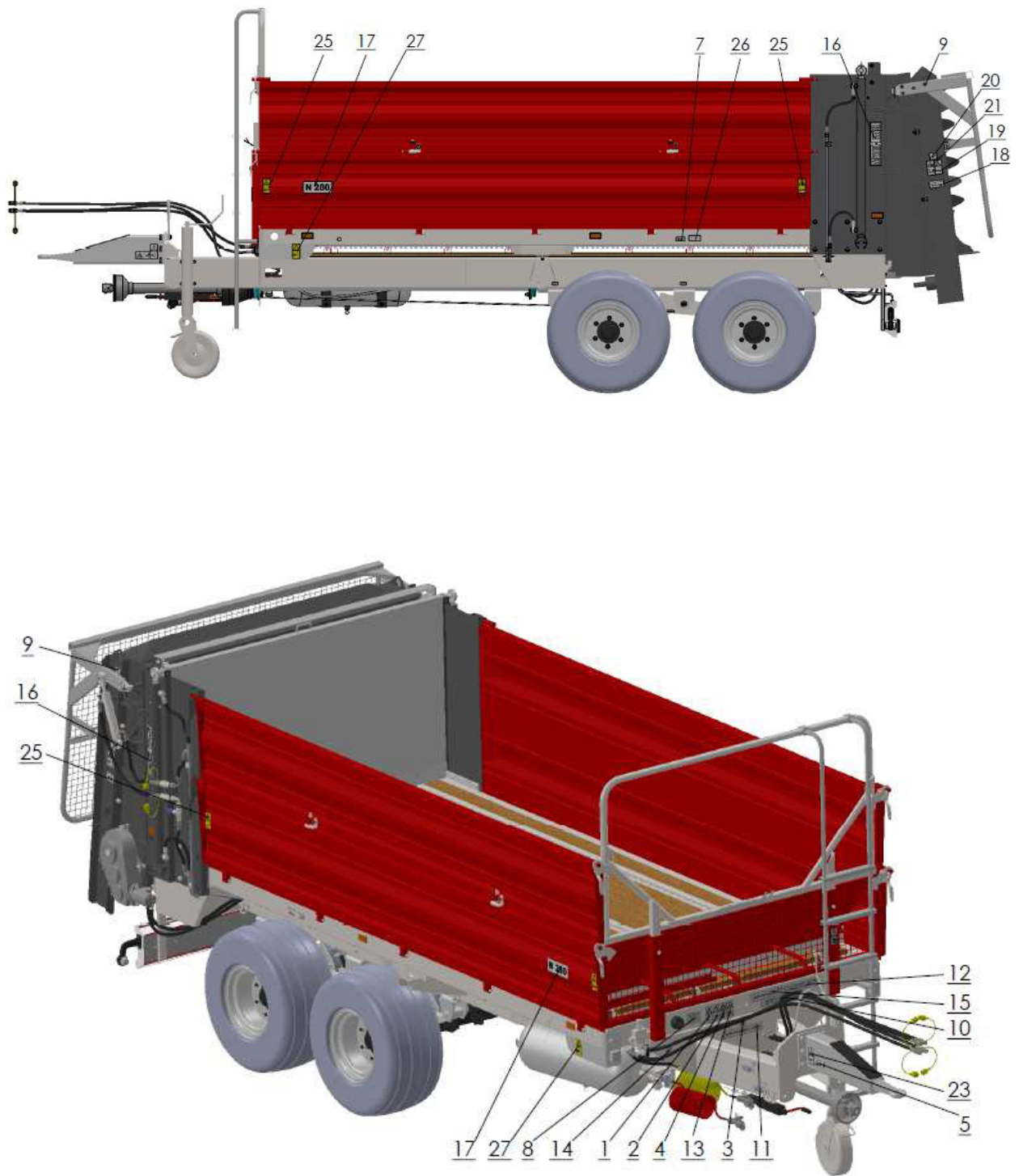

Fig. 1. Locations of the information and warning signs

## **4. INTENDED USE**

The N280 spreaders are intended for spreading of manure, peat, compost, etc. and transportation of crops within farms and on public roads. The machines are self-dumping and coupled with farming tractors only by the lower hitch.

Spreaders are equipped with gates and facilitate transport of loose bulk loads by preventing its spillage from the load body.

The spreaders can only be operated and serviced by adults who have read and understood these Operating Instructions, specifically the information in section "Safety Instructions".

Servicing and operating this product against the Operating Instructions releases the manufacturer from any liability resulting from improper use and makes the warranty null and void.

The manufacturer forbids any unauthorized modification of the spreader design. Any modifications of the design release the manufacturer from any effects of such changes and may void the warranty.

In the case of any doubts regarding the use of the spreader, consult your supplier or the manufacturer's service department.

## **5. OPERATION OF SPREADERS**

### **5.1. Coupling the spreader with the tractor**

The spreader is coupled with the tractor in the following way:

- couple the hitch lug with the tractor coupler;
- fit the telescopic jointed shaft and use the chains to secure the shaft guard from turning during operation;
- connect the spreader electrical system to the tractor electrical system and secure the plug from decoupling;
- connect the spreader's drive hydraulic system to the terminal of the tractor hydraulic system by twisting the quick-release coupling nut clockwise home;
- connect the pneumatic system of the service brake;
- connect the body gate hydraulic system;
- check that the connections between the spreader and the tractor hitch, electrical connections, service brake connections and the connections between various systems and drives;
- if all systems are functional, release the parking brake and lift the support.

THE FOLLOWING IS STRICTLY FORBIDDEN:

- coupling the spreader with the tractor by using any other coupling than the lower hitch. The machine must have the parking brake engaged when it is being coupled;
- pressurized hydraulic systems of the tractor when coupling the trailer – all control valves must be set to neutral. When the quick-release coupling nut is tightened, the coupling is opened and high oil pressure may result in a leak. Tighten the nuts until resistance is felt to ensure that the couplings are fully sealed.

Disconnecting the spreader:

Before disconnecting the spreader from the tractor, first engage the machine parking brake and lower the support wheel – see fig. 2 item 1.

The support wheel stabilizes the spreader when it is loaded or not.

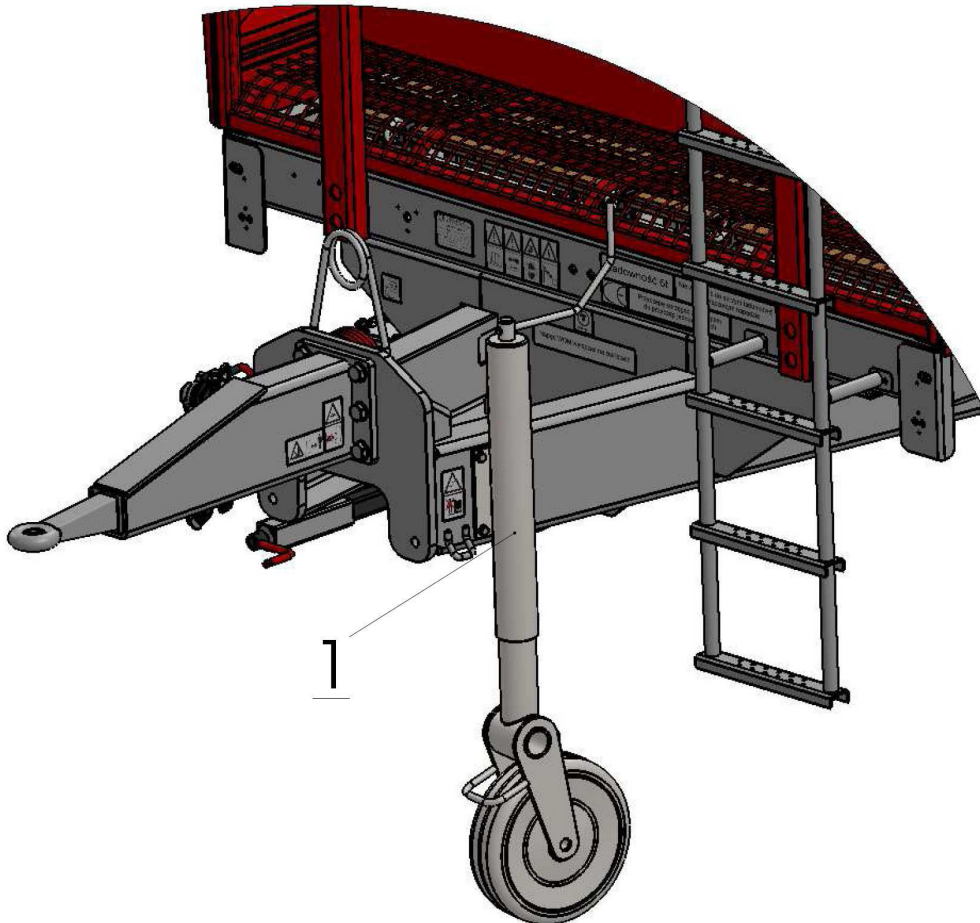

Fig. 2 N280 spreader's support wheel.



Do not disassemble the support or rest the machine on makeshift supports.



Do not leave agricultural equipment on slopes or any other terrain inclinations without securing it against accidental rolling.

### 5.1.1. Adapter drive

The adapter drums are driven by the telescopic jointed shaft, which couples the tractor PTO with the two-sectional drive shaft and the telescopic jointed shaft located before the adapter. Spreaders with the A4VS adapter (with four vertical worm drums) have an articulated shaft with a slip clutch.

The telescopic jointed shafts used in the spreader:

Machine Type	Shaft designation	Rated torque	Rated length	Transferred output	Overload clutches
		Nm	mm	kW	Nm
N280		540	1745	30	1600
N280/1					
N280/2		900	920	50	1500



The shaft must bear the "CE" marking. Use only the shafts that are equipped with complete guards.



Do not use the telescopic jointed shafts with damaged guards.

When the machine is properly operated, the overload clutch should not engage. If the clutch engages, the machine is overloaded. If the material is not ejected during operation, the shear pin overload clutch is engaged. Remove the cause of overload (e.g. a cord wound on the drums, objects jammed between the drums, etc.). When the drive system is overloaded, the pin in the coupling shaft is sheared.



Before attempting to clear the jam, turn off the tractor engine and remove the ignition key.



When the overload cause has been cleared, prior to turning the machine on and directly before turning on the drive, reverse the conveyor shift direction for a short moment. (The conveyor shift direction is changed by changing the feed direction with the directional control valve of the tractor.)



### 5.1.2. Commissioning and running-in

Do the following before commissioning the spreader:

- read and understand the operating instructions in full;
- assemble the machine in accordance with the intended work;
- check the tightness of all threaded connections and the tension of chains;
- supply lubricants at the lubrication points;
- check the transmission oil level and top up if required – use HIPOL–15 oil;
- park the spreader and run it in initially without the load.

The initial running-in should last approximately 15 minutes at decreased rotational speed of the tractor drive. During this procedure ensure that all systems work smoothly and without jamming and excessive noise. When the initial running-in is finished, make sure that the fastening bolts did not become loose and check the tension of chains.

Lubricate at all lubrication points twice a day for the first 20 operating hours. Replace the transmission oil afterwards and check the tightening of bolts and chain tension. Readjust if necessary.

The manure can be mechanically loaded on the spreader. In order to fully use the spreader load capacity when working with long-straw manure, it is allowed to fill the load body up to 10 cm above the upper edge. Do not load the long-straw manure directly on the adapter drums – this may damage the drive. The load must not hang over the body sides. When the work is finished or if needed, remove the manure which may accumulate on the rear beam in the area of socket wheels and on the spreader drums, as well as on the drive shafts. Excessive accumulation of dirt can overload the tractor and elongate the conveyor chains. In order to achieve the best spreading parameters (i.e. width and uniformity), keep the PTO speed on the tractor between 920 and 1000 rpm.

#### **Warning:**

**Clean the spreader only when the drive is decoupled and the tractor is stopped. Exercise extreme caution when cleaning with the raised gate. Decouple the telescopic jointed shaft from the tractor.**

#### **Warning:**

**When the spreader works on the field, the material in the load body moves towards its rear end. This slowly decreases the pressure on the tractor hitch and lowers the wheel grip of the rear tractor wheels. This may reduce the tractor's pull force on difficult terrain (i.e. hilly or damp ground). Due to this fact it is advised perform the final phase of unloading the load body of the spreader when moving down a slope or on a flat (level) terrain.**

## 5.2. Electrical system

The spreader is equipped with a 12 V electrical system supplied by the tractor. Before entering a public road, always make sure that the lighting system is functional. The electrical system powers the two front sidelamps, the lamp clusters and the clearance lamps.

### 5.3. Load body gate control

The load body gate is lifted and lowered hydraulically by the secondary hydraulic system of the tractor.

### 5.4. Floor conveyor

#### 5.4.1. Hydraulic drive of the floor conveyor

The floor conveyor system of the spreader is hydraulically driven by the transmission gearbox powered by the hydraulic motor, which in turn is driven by the pressurised hydraulic oil from the tractor's hydraulic system.

The shift speed of the floor conveyor (i.e. the manure spreading output) is controlled and adjustable by setting the adjustment screw (2) of the flow controller (1) installed in the right section of the spreader front panel. Turning the adjustment screw clockwise increases the conveyor shift speed, while turning it counter-clockwise decreases the shift speed. When the spreader is unloaded and the material mass decreases, the conveyor shift speed slightly increases at the same time.

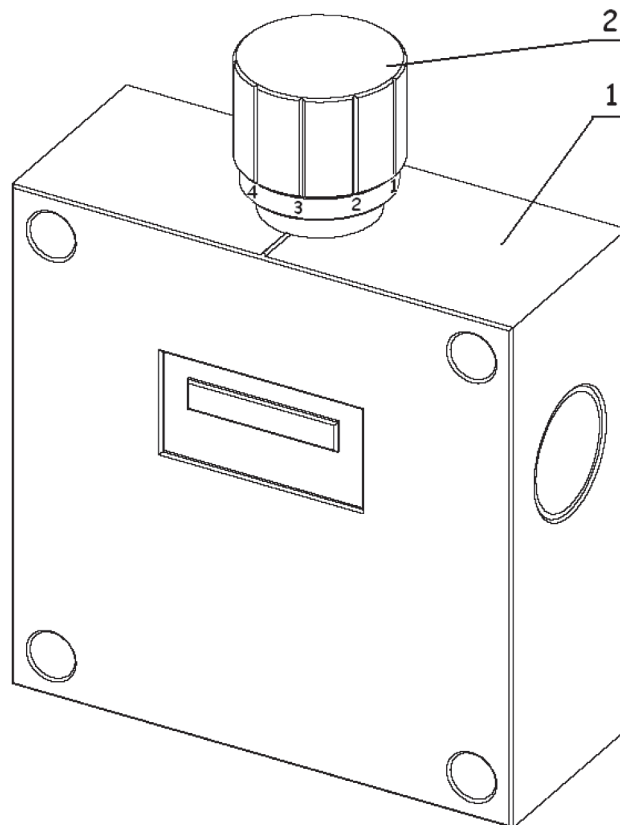

Fig. 3. Flow controller

The only shift speed which is pre-set is the reverse shift speed of the conveyor. The conveyor shift direction is switched by changing the feed direction on the tractor (with the directional control valve of the tractor).

## 5.4.2. Manure dosing

The floor conveyor output for the manure with a specific gravity of 950 kg/m<sup>3</sup>:

Setting no.	Conveyor output kg/s
1	0.0
2	0.0
3	6.4
4	14.3
5	25.7
6	38.4
7	50.1
8	64.7
9	76.8
10	99.5

The manure dosing (at the specific gravity of 950 kg/m<sup>3</sup>), depending on the floor conveyor shift speed and the actual service speed is presented in the following table:

Setting no.	Conveyor output [kg/s]	Spreader service speed [km/h]						
		4	5	6	7	8	9	10
		Manure dose [T/ha]						
3	6.4	7.2	5.8	4.8	4.1	3.6	3.2	2.9
4	14.3	16.1	12.9	10.7	9.2	8.0	7.2	6.5
5	25.7	29.0	23.2	19.3	16.5	14.5	12.9	11.6
6	38.4	43.2	34.6	28.8	24.7	21.6	19.2	17.3
7	50.1	56.4	45.1	37.6	32.2	28.2	25.1	22.6
8	64.7	72.8	58.2	48.5	41.6	36.4	32.3	29.1
9	76.8	86.4	69.2	57.6	49.4	43.2	38.4	34.6
10	99.5	112.0	89.6	74.6	64.0	56.0	49.8	44.8

The manure dosing (at the specific gravity of 950 kg/m<sup>3</sup>), depending on the floor conveyor shift speed and the actual service speed is presented in the following table:

Setting no.	Conveyor output [kg/s]	Spreader service speed [km/h]						
		4	5	6	7	8	9	10
		Manure dose [T/ha]						
3	4.1	4.6	3.7	3.1	2.6	2.3	2.0	1.8
4	9.1	10.2	8.2	6.8	5.9	5.1	4.6	4.1
5	16.3	18.3	14.6	12.2	10.4	9.2	8.2	7.4
6	24.2	27.2	21.8	18.2	15.6	13.7	12.2	10.9
7	31.6	35.6	28.4	23.7	20.3	17.8	15.8	14.2
8	40.8	45.9	36.8	30.6	26.3	23.0	20.4	18.4
9	48.5	54.6	43.7	36.4	31.2	27.3	24.3	21.8
10	62.9	70.7	56.6	47.2	40.4	35.3	31.4	28.3



Note: Take extra caution when performing the adjustment. Turn off the tractor engine, remove the ignition key and engage the parking brake of the tractor.

## 5.5. Adjustment of conveyor chain tension

The conveyor chains are adjusted by the stretcher screws (see fig. 4 item 1) located on the stringers of the spreader's top frame. The adjustment includes rotating screw (1) so as to obtain the correct chains tension. But if tension of one of the chains is different, correct it using coupler (3). After the screw (1) adjustment range is reached, adjust the support for wedges (2) and (4) using screws shown in fig. (5). To check the chains tension, raise the chain in the location in the middle of the length of the body. The distance of the chain from the floor should be 1–6 cm when lifted. If the chain is lifted above the maximum stretcher adjustment value, replace the chain with a new one.

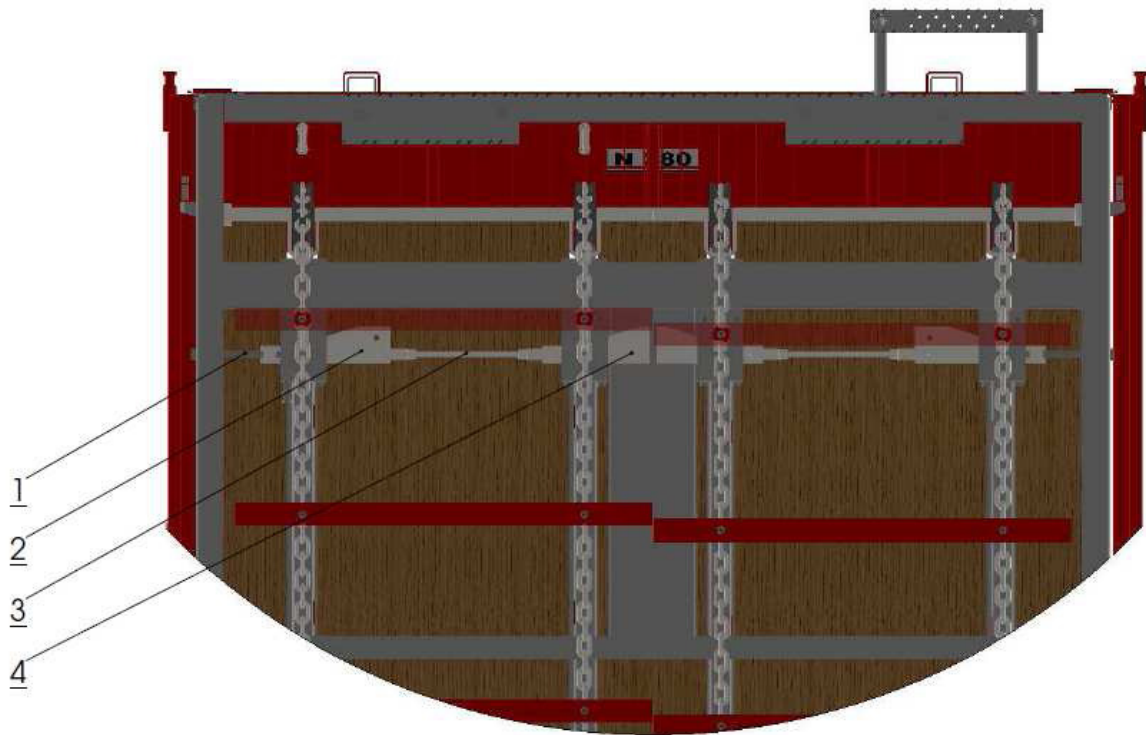

Fig. 4. Tensioning the conveyor chains.

To correct the setting of tensioners after the adjustment range of screw (1) fig. 4 is reached, shift the wedge supporting blocks using screws (1) fig. 5. Counter the screw with nut (2) fig. 5.

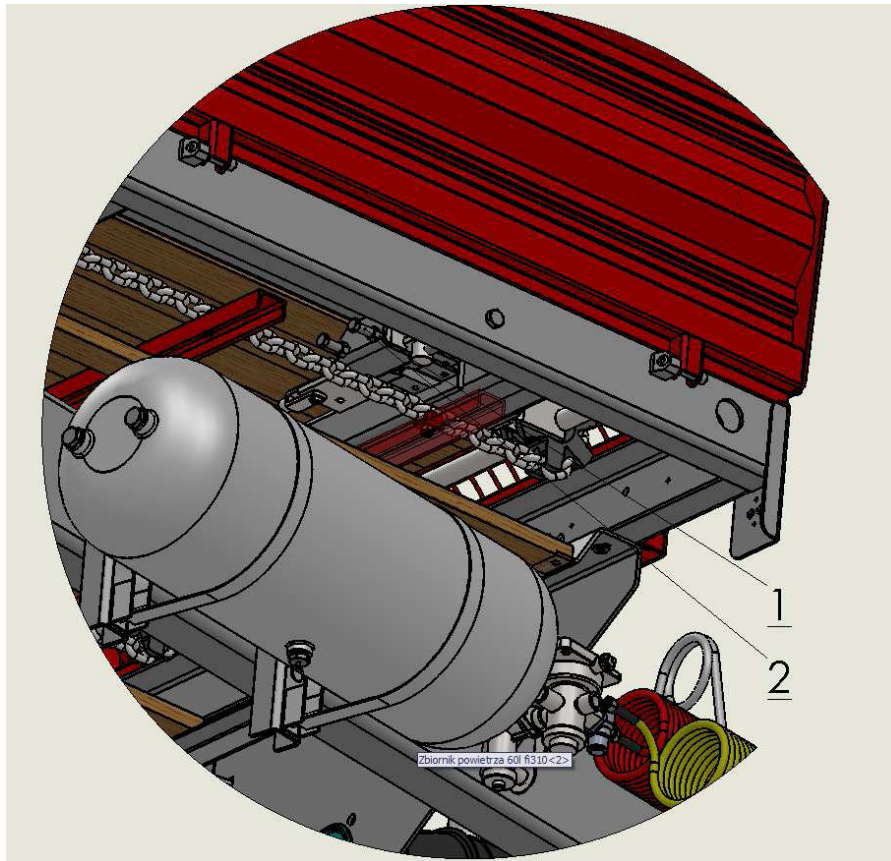

Fig. 5. Correcting the tensioners setting.

## 5.6. Spreading adapter

The adapter consists of a frame on which four worm drums driven by the telescopic jointed shaft, the drive shafts and the transmission gearbox installed in the adapter frame. The drive is transmitted from the tractor PTO.

The adapter frame is connected to the spreader frame by six or eight M14 bolts (depending on version).

Adapter disassembly procedure:

- decouple the telescopic jointed shaft from the adapter transmission;
- decouple the hydraulic quick-couplings of the net raising cylinder;
- open the locks holding the adapter unit;
- use a lifting device with the minimum capacity of 600 kg to remove the adapter.



Exercise extreme caution when assembling and disassembling (repairing) the adapter. Due to the large weight of these components, use suitable lifting equipment. The assembly and disassembly procedures must be performed by two persons.



The vertical adapters and the attachment must be handled with the use of a lifting device with the minimum capacity of 1200 kg.

## 5.7. Brakes adjustment

### 5.7.1. Parking brake adjustment

The parking brake is adjusted by setting the initial cable tension by making a loop of a suitable length on both cable ends.



The parking brake is functioning when it is capable of stopping the loaded spreader on a slope with a grade of 18°.

### 5.7.2. Service brake adjustment

The braking system must be suitably adjusted to compensate the wear of the brake shoe linings. If the actuator idle stroke is excessive, adjust as follows: remove the cotter pin (3), remove the crown nut (1), loosen the brake expander lever (2) and shift the lever in the direction opposite to the braking motion in such way that the lever is perpendicular to the brake actuator when the latter is in the braking position. If the brake linings are excessively worn, replace them. After each adjustment make sure to tighten the crown nut and secure it with a new cotter pin.

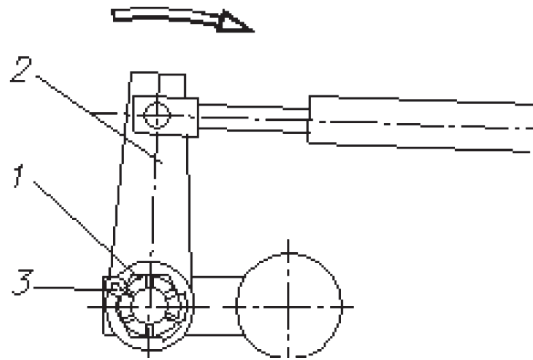

Fig. 6. Service brake adjustment



When the brakes are properly adjusted, the spreading unit (tractor + spreader) with the rated load at 30 km/h should stop at 10 m from the brake engagement and the wheels should brake uniformly.

When the spreader has made the first 100 km, check the brakes and adjust them if necessary.

## 5.8. Adjustment of the land wheels clearance

When the new spreader has made the first 100 km and after every next 1000-1500 km of its operation, check the clearance of the land wheel bearings and adjust it if necessary.

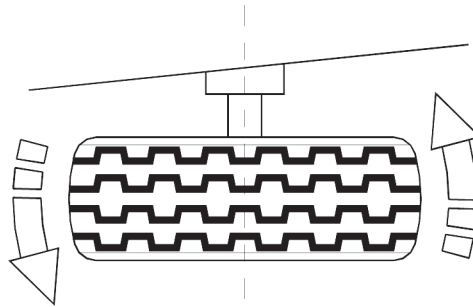

Fig. 7. Checking the clearance of the land wheel bearings.

### Check the clearance of the land wheel bearings as follows:

Couple the spreader with the tractor on the lower hitch and engage the tractor parking brake. Jack up one side of the spreader to lift the wheel from the ground on this side and secure the spreader from falling. Attempt to turn the wheel in order to check the bearing clearance, see Fig. 7. If the wheel clearance is too large, remove the hub cap, remove the cap seal and the crown nut clevis pin. Rotate the wheel and tighten the crown nut at the same time until the wheel stops. Now loosen the crown nut by 1/6-1/5 of the full turn, i.e. to the nearest clevis pin groove. Install a new clevis pin, new seal and mount the hub cap. Repeat for the other spreader wheels.

## 6. MAINTENANCE AND SERVICING

### 6.1. Hydraulic system servicing

The hydraulic system oil of the spreader and the external hydraulic system oil (tractor) must always be of the same grade.



DO NOT use different oil grades. The system has the SAE 80W viscosity oil.



Caution! The hydraulic hoses must be replaced after 6 years from the date of manufacture.

The spreader hydraulic system must be absolutely leak-tight. If there are oil leaks at the hydraulic connections, tighten them; if the leak persists, replace the hose or the connection fittings. The hydraulic hoses must also be replaced upon any mechanical damage.

The condition of the hydraulic system must be monitored continuously throughout the operating life.



Caution! The hydraulic oil must be replaced in accordance with the operating manual of the coupled tractor, but at least every two years.

## 6.2. Pneumatic system servicing

Periodically check the pneumatic system tightness. Thoroughly inspect every connection. Check the leak-tightness of the system at the rated pressure of approx. 600 kPa (6.0 kG/cm<sup>2</sup>). After decoupling the tractor, the 10-minute pressure loss in the vessel should not exceed 2% of the initial pressure value which is set directly after decoupling the trailer. If any lines, seals or other system components are damaged, the compressed air will escape from the damaged points, producing a distinctive hissing noise. Replace any damaged seals or lines which cause the leaks.

If the leak is located at the actuator, replace the device. If any mechanical damage is found on the vessel (e.g. dents, cracks, etc.) or if the vessel has been exposed to high temperature, replace it.

Drain all water from the pneumatic system at least twice a year, especially before winter. To do this, press and hold the lever that extends from the drain valve screwed into the bottom part of the tank until the water flow stops. Release the lever. The tank should remain leak tight.

## 6.3. Periodic maintenance

The periodic technical inspection of the spreader should be performed every 50 operating hours.



Due to safety considerations, it is necessary to perform functional tests of the service and parking brakes, the power transmission system and the wheel system.



## 6.4. Lubrication

Lubrication of the spreader systems in accordance with the lubrication schedule ensures better performance and protects from premature wear.

Follow these rules when lubricating:

- before attempting to lubricate, thoroughly clean all grease nipples and areas around the lubrication points from mud and dust;
- feed the grease into the nipple until the fresh grease flows out of the spaces between mating parts;
- apply fresh grease on the land wheel bearings by first removing the wheels with the hubs – then wash the hubs and pivots with Diesel fuel and fill the hub lubricating chambers with fresh grease;
- replace the transmission gearbox oil directly after stopping the spreader (the oil temperature will be higher, which facilitates draining it from the gearbox);
- flush the gearbox with Diesel fuel before priming with fresh oil;
- lubricate the telescopic jointed shafts in accordance with the shaft operating manual.

Perform the lubrication of the wheel bearing during the inspection and adjustment of the brakes. When replacing the wheel hub bearings, remove all grease from the hub chambers. After each year of operation, remove the hubs with their bearings, wash the bearings and the hub chamber and then refill with fresh grease. The lubrication points are showed in the lubrication diagrams.

All lubrication points indicated with stickers must be greased or checked for grease level before starting the spreader. Use LT-42, LT-43 or any other high-performance bearing grease. The transmission gearboxes are primed with HIPOL 15 oil.

The socket wheel grease nipples of the floor conveyor do not require lubrication, since self-lubricating bushings are installed in these assemblies. Force feed grease to clean the mating surfaces during inspection or after removing the adapter.

### Lubrication schedule

Lubrication point no.	Name of the spreader component to be lubricated	Lubricant type	Lubrication method
1	Conveyor stretcher wheels	LT-42 or LT- 43	lubrication points (not required)
2	Spreader rear shaft bearing	LT-42 or LT- 43	lubrication points
3	Expander bearing	LT-42 or LT- 43	lubrication points
4	Road wheel bearing	LT-42 or LT- 43	periodic replacement
5	Conveyor chains	Hipol 15	apply to the surface
6	Support	LT-42 or LT- 43	periodic replacement
7	Intermediate drive bearing	LT-42 or LT- 43	lubrication points
8	Transmission gearbox	Hipol 15	periodic replacement
9	Suspension spring pin	LT-42 or LT- 43	lubrication points

## 7. TECHNICAL CHARACTERISTICS

Symbol:	N280	N280/1	N280/2
Load capacity [kg]:	6,000	8,000	10,000
Overall length [mm]:	7477		7977
Overall width [mm]:	2850		
Overall height [mm]:	3110	3220	3210
Loading space: length [mm]:	4120		4620
width [mm]:	1960		
height [mm]:	1000	1100	1200
Loading space volume [m <sup>3</sup> ]:	8.07	8.9	10.8
Hitch lug distance [mm]:	top		
Wheel system:	Spring tandem		
Wheel track [mm]	2200		
Hydraulic drive of the floor conveyor:	Slat floor conveyor, hydraulically driven with shift speed adjustment		
Kerb weight [kg]	3280 including: - tow bar lug load: 200; - per axle: 3080;	3460 including: - tow bar lug load: 200; - per axle: 3260;	3660 including: - tow bar lug load: 260; - per axle: 3400;
Permissible overall weight [kg]	9280 including: - tow bar lug load: 3000; - multiple axle load: 6280;	11460 including: - tow bar lug load: 3000; - multiple axle load: 8460;	13660 including: - tow bar lug load: 3000; - multiple axle load: 10660;
Adapter type:	Vertical w/four spreading drums, A4VS		
Adapter weight [kg]	440	470	470
Adapter drive:	Tractor PTO (540 Nm), part no. 6R-602-7-BA-K601		
Adapter telescopic jointed shaft	540 Nm w/friction clutch, part no. 8R-802-3-DA-C803		
Spreading path width [mm]:	12,000 – 15,000		
Effective spreading width [mm]:	8,000		
Internal gate	Hydraulically actuated		
Ladder	Standard accessory, located in the front left side of the load body		
Tyres	400/60-15.5 14PR	500/50-17 14PR (19.0/45-17 14PR)	19.0/45-17 14 PR
Tyre pressure [kPa]	300		
Wheel chocks [pcs]	2		
Braking system	Mechanical, drum-type: - pneumatic-controlled service brake, two-line system, for all 4 wheels; - mechanically-controlled parking brake, for 2 wheels of the front tandem axle		
Driving tractor [HP]	Minimum 70	Minimum 80	
Electrical system [V]	12 – feed by the driving tractor		
Hydraulic system pressure [MPa]	Maximum 18		
Transport (transit) speed [km/h]	30		
Service speed [km/h]	4÷10		

## 8. MAINTENANCE, CARE AND STORAGE

When the work season is over, do the following:

- wash the spreader;
- repair all paint coat decrements;
- lubricate all lubrication points;
- protect all quick-release couplings of the hydraulic system from contamination (e.g. by wrapping in foil);
- check all threaded and pin connections (re-tighten or repair as required);
- after lifting the spreader above the ground and setting it on the props, reduce the tyre pressure by approx. 0.1-0.15 MPa (1-1.5 atm);
- check the transmission oil level and refill to the bottom edge of the filling port;
- clean and preserve the telescopic jointed shaft;
- identify all parts which need to be replaced;
- store the machine under a roof if possible.



Before attempting to work on any systems of the spreader connected to the tractor with the drive-shaft, turn off the tractor engine, remove the ignition key and engage the tractor parking brake.

Decouple the drive-shaft before servicing (cleaning, maintenance, repairs) the machine. Engage the spreader parking brake and chock the wheels.

**Open the upper wall to enable entering and exit from load body when entering the body using the ladder to perform maintenance.**

## 9. DISMANTLING, DISPOSAL AND ENVIRONMENTAL PROTECTION

If the product is repaired, dispose of all worn-out parts at a scrap collection point. Follow all applicable OHS regulations for repair and replacement of worn-out subassemblies. Dispose of the entire product at a recyclable materials collection point.

Each identified hydraulic system fault, i.e. oil leaks, must be immediately rectified to prevent environmental pollution. Do not let the oil to be spilled on the ground when replacing the fluid. Store the used oil in sealed vessels (e.g. used for fresh oils) and periodically dispose of its at fuel stations.

**Only the personnel experienced in the design and operation of the machine is authorised to dismantle it. Follow the general safety precautions for agricultural equipment servicing during disassembly (repairs). Due to the large weight of components (over 20 kg), use suitable lifting equipment for disassembly.**

Do not leave any worn-out or damaged parts from repairs or disposal on the field or farm premises. Such items must be stored at a designated area (with restricted access of personnel and animals) and periodically disposed of at a scrap collection point.

Dispose of the entire machine at a specialist facility which handles the dismantling of machines and equipment. If disposing of the machine on your own, segregate all dismantled components in accordance to the material type: rubber, ferrous metals and non-ferrous metals. Submit all rubber parts for re-use (recycling or disposal).

## 10. EQUIPMENT

Item	Details	Drawing No. or standard	N280, N280/1, N280/2
1.	Wheel chocks	-	2
2.	Telescopic jointed shaft	6R-602-7-BA-K601 8R-802-3-DA-C803	1
3.	Operating Instructions, warranty card	-	1

Make sure that all accessories are present upon purchasing the spreader.

Warning:

Item 3 is supplied in a plastic bag.

## 11. USE

The manure spreader is fully adapted for public traffic by featuring a pneumatic braking system, parking brake and electrical lighting system. **The spreader can only be operated by adults with a valid Category T driving licence (for tractors). Prior to travelling, check that the brakes and lighting work properly. Do not exceed the permissible load capacity and driving speed.**

Travel on public roads only when the rear guard is closed and the triangle identification emblem is present. The gate must be lowered. During operation, the guard opens when the gate is lifted.

### INFORMATION!

1. Exercise extreme caution when travelling on public roads and follow the valid traffic code.

## 12. DESIGN AND OPERATING PRINCIPLE OF THE SPREADER

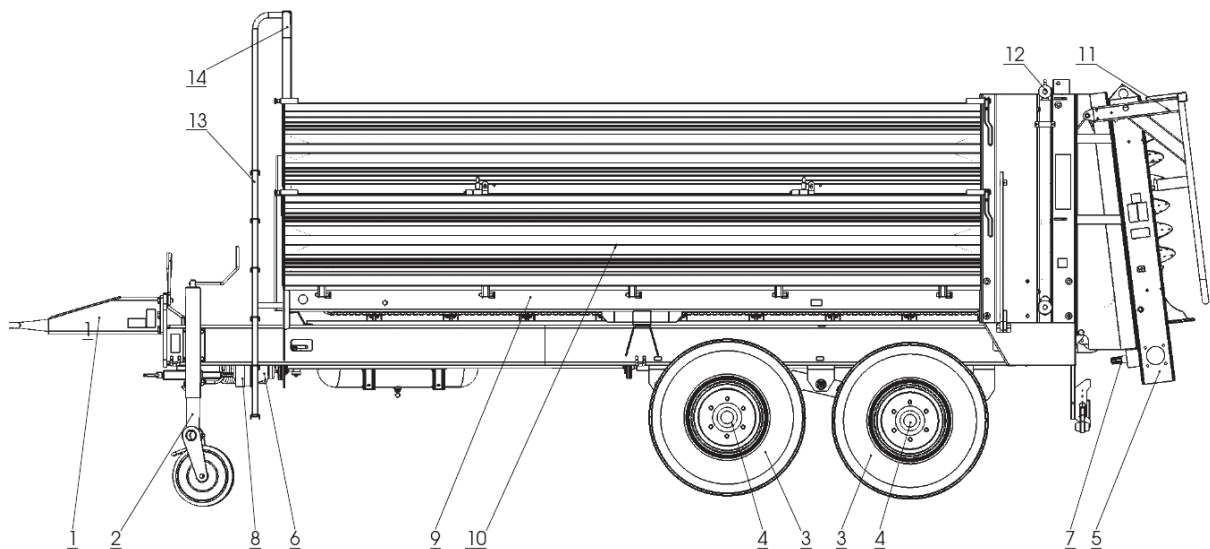

Fig. 8. Design of the spreader.

1-hitch, 2-support, 3-land wheel, 4-axle, 5-adapter, 6-adapter power system, 7-adapter jointed shaft, 8-joint guard, 9-top frame, 10-opening side walls, 11-rear wall, 12-bolt, 13-ladder, 14-front mesh.

The N280 spreader is a machine adapted for coupling with the tractor's upper transport hitch. The machine consists of the following main assemblies:

- hitch system (1);
- load body supported on top frame (9) with opening side walls (10),
- spreading adapter (5);
- wheel system (4);
- hydraulic system.

The manure spreader is intended for transport and spreading of loose manure. The manure spreader design includes the load body with side panels and a chain conveyor which moves on the floor. The rear end of the load body is closed by an articulated rear end wall with rubber seals along its bottom edge. The end wall is installed on guides and actuated or positioned by hydraulic actuators. A horizontal conveyor drive shaft with socket wheels is installed in the rear section of the load body. The shaft is propelled by a reduction gear coupled with a hydraulic motor. There is a manure spreading adapter at the end of the load body, which consists of four vertical worm screws with bolted shredding blades.

The spreader should be charged uniformly to ensure an optimum spread. The charging (loading) height must not exceed the spreading adapter clearance height. Make sure that no larger solid bodies (stones and alike) are present in the manure to prevent damage.

Prior to spreading, make sure that the mesh guard is installed on the front panel which protects the operator against injury from falling objects, e.g. stones.



**INFORMATION!**

No person is allowed to remain on the machine or within its operating area when it is working.

In order to obtain an even manure spread, do the following actions in the indicated order:

- first increase the PTO's rotational speed to 540 rpm and then turn on the floor conveyor;
- spread enough manure in standstill until the required amount is fed to the spreading worm screws;
- then shift into the suitable gear and begin work.

Keep the PTO speed at 540 rpm to achieve the optimum spreading pattern. The spread layer thickness can be adjusted by changing the floor shift speed and the spreader charging ratio. When making a return on the field, decouple the PTO which will protect the jointed shaft and ensure a uniform spread. Install new shear pins if the overload protection engages during the manure spreading and the shear pins of the shaft are damaged. Stop the PTO and the tractor engine before replacing these components! The most common cause for pin shearing is jamming of the spreading adapter by stones or large, hard chunks of manure.

# METAL-FACH

16-100 SOKÓŁKA, POLAND

UL. KRESOWA 62

## WARRANTY CARD MANURE SPREADER N280

The warranty service is provided on behalf of the manufacturer by:

.....

*filled out by the seller*

Date of manufacture.....

Date of sale .....

Serial number.....

Signature of the Seller .....

Customer's name and surname .....

Address .....

Item	Service call date	Date of completion	Description of completed service actions and replaced parts	Service technician name	Service stamp